

University of California
Berkeley

College of Engineering
Department of Electrical Engineering
and Computer Sciences

Professors : N.Morgan / B.Gold
EE225D

Spring, 1999

Pitch Perception

Lecture 17

Some Definitions of “Pitch” (Webster).

Any of various...viscous substances obtained as residues in the distillation of tars or other organic substances.

To erect, e.g. a tent

To throw, fling

To deliver a baseball to a batter

To toss coins

To sell, peddle or advertise in a high-pressure way

* *A particular highness or lowness of tone*

* *A particular musical note*

To utter...with a glibness typically marked by exaggeration

To chip (a stone) so as to have straight lines and a flat surface

To fall headlong (pitch forward)

Model the auditory systems to explain pitch measurements.

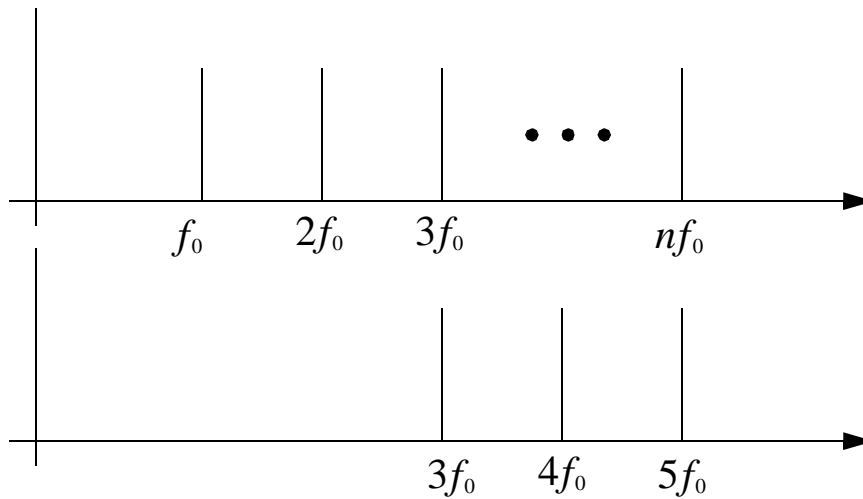
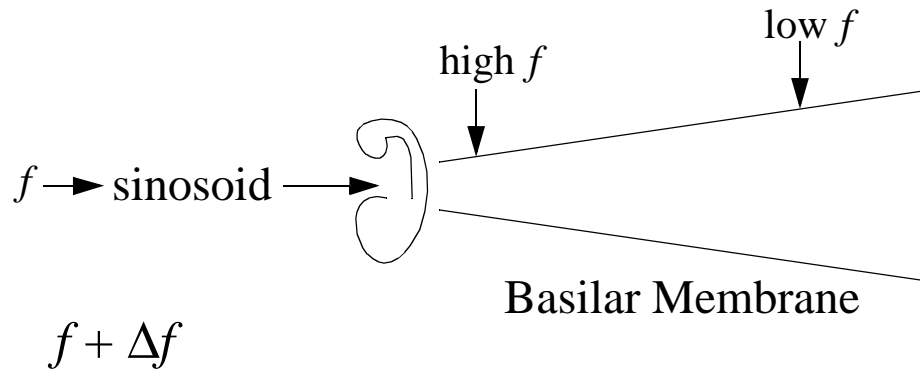

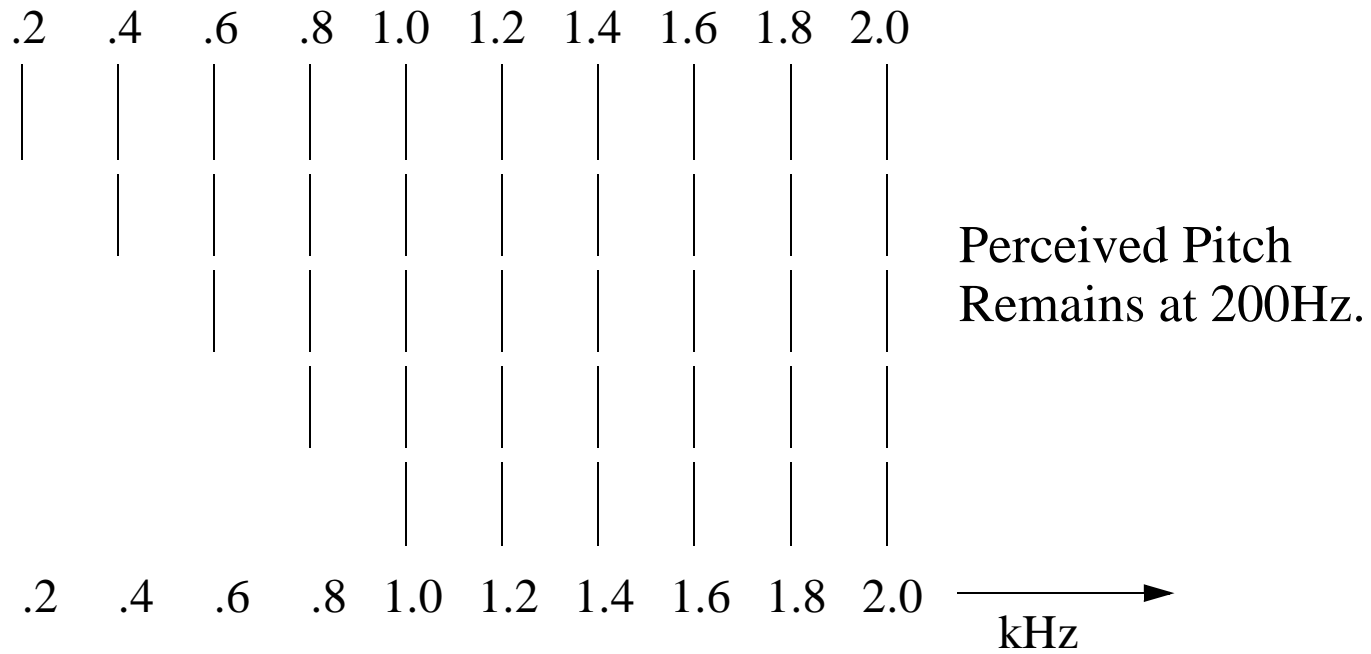
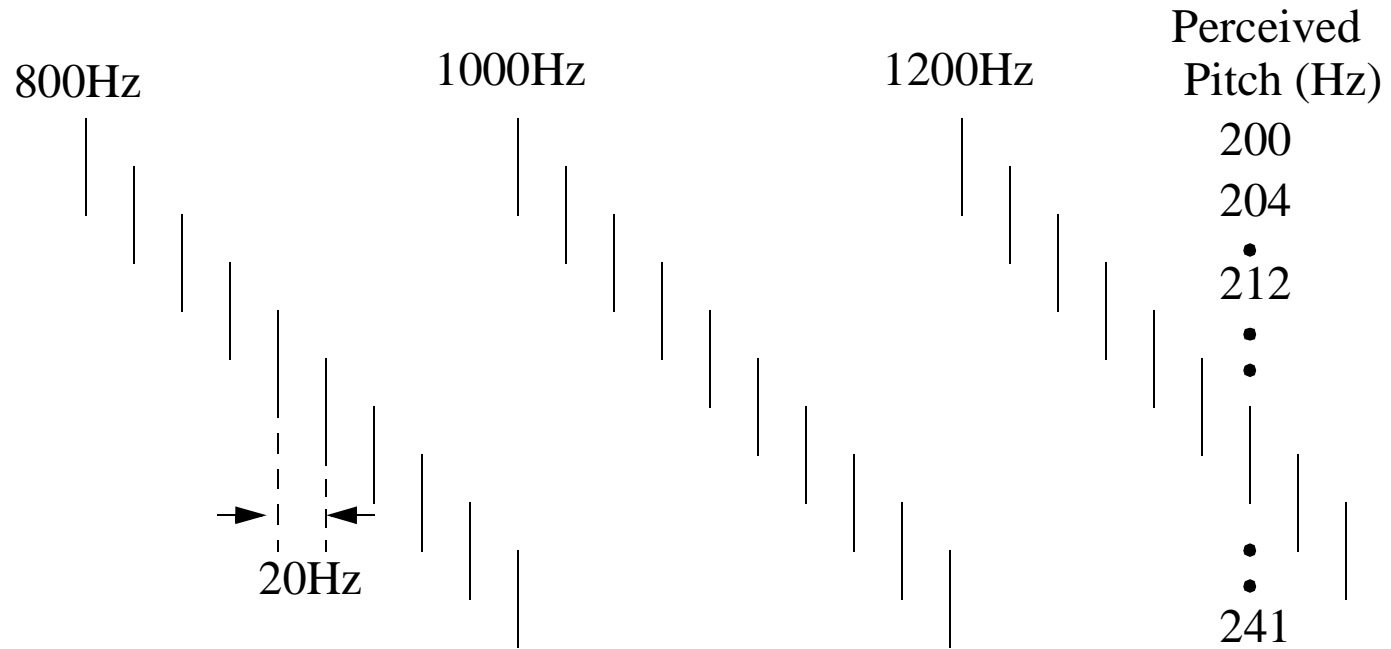

Figure 16.4 : Virtual Pitch Demonstration.



Shift of Virtual Pitch ...Demonstration 1

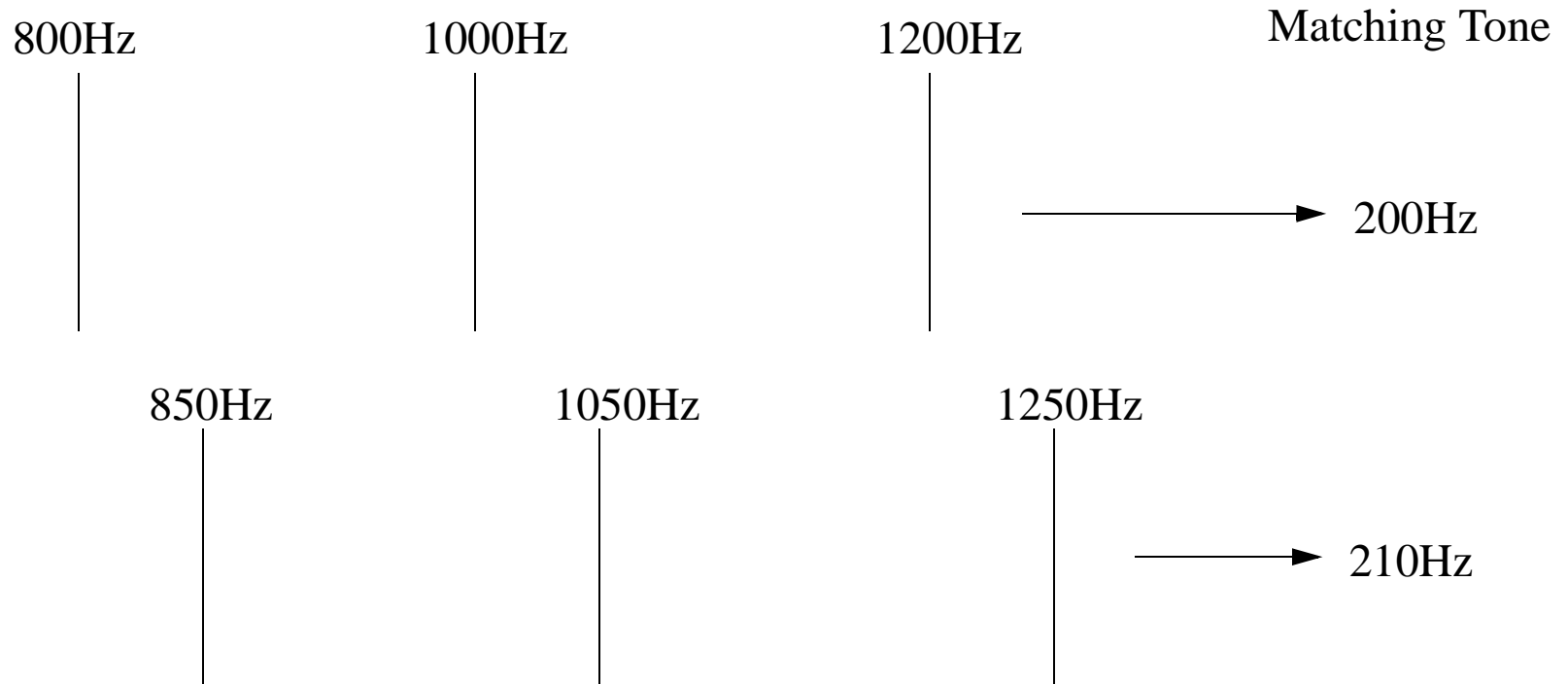
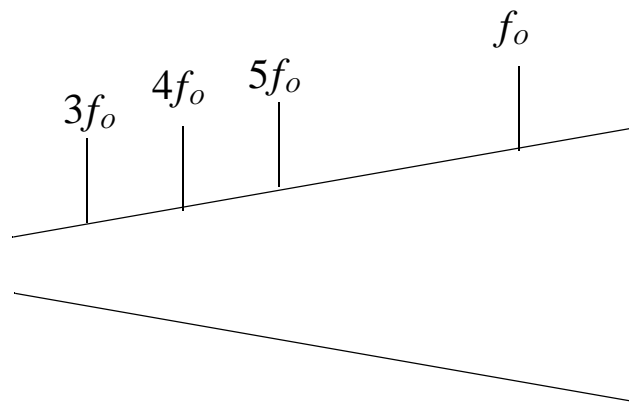

Figure 16.11 : Shift of Virtual Pitch...Demonstration 2.



Schouton \Rightarrow Periodicity

Helmholtz \Rightarrow Place

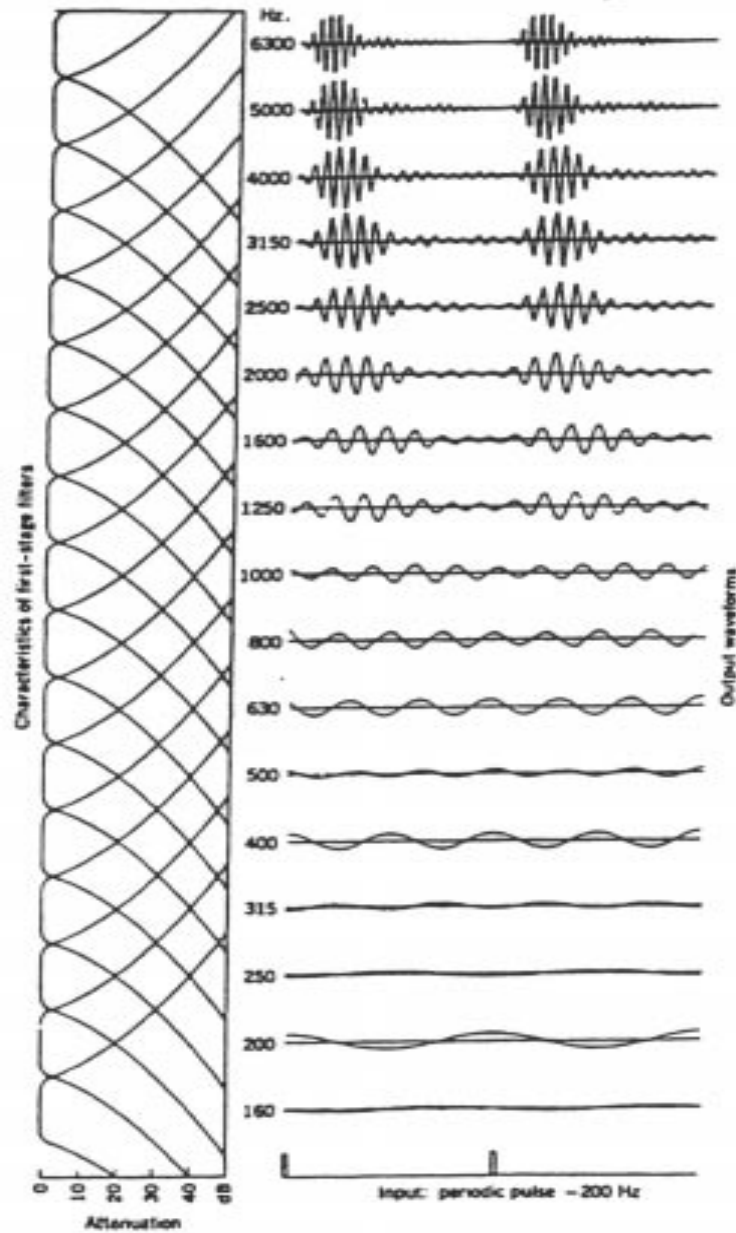

Figure 16.5 : Schouten's Depiction of
BM Responses to a Periodic 200Hz
Pulse Train.

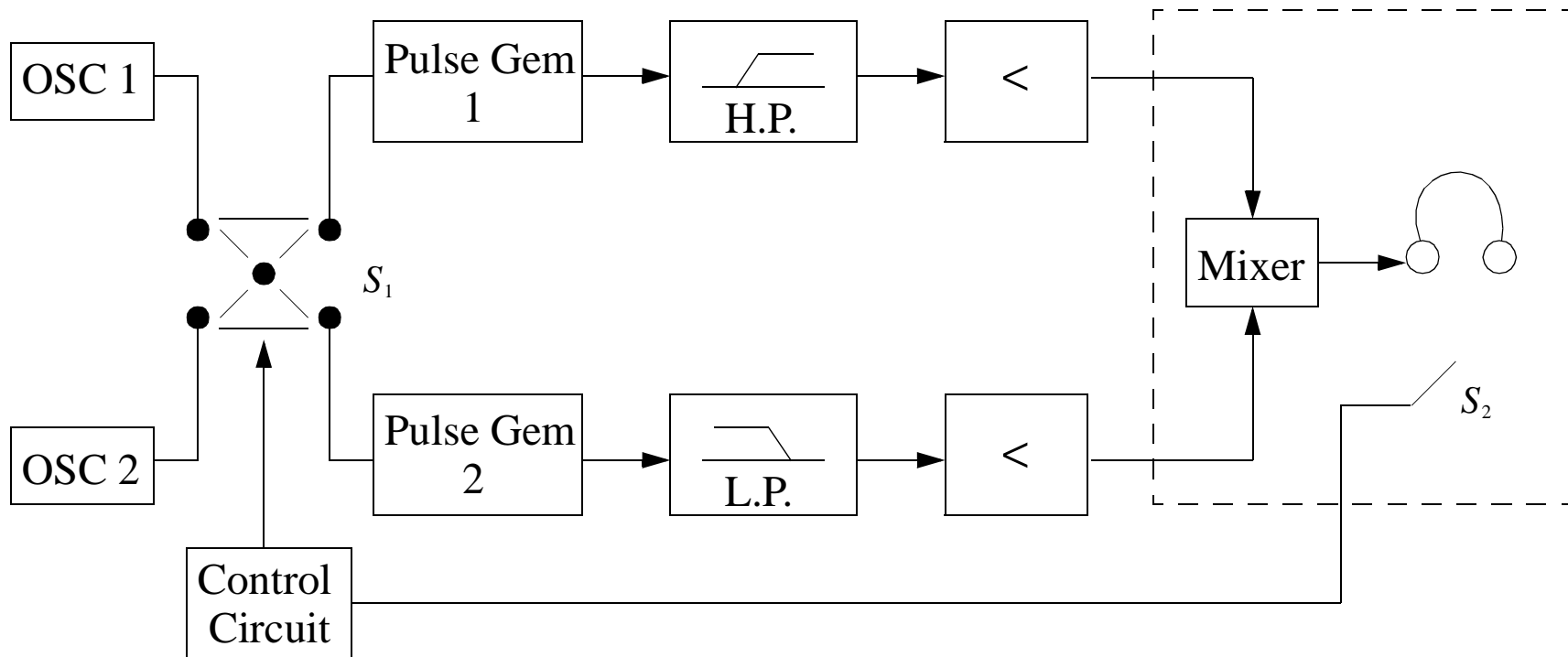
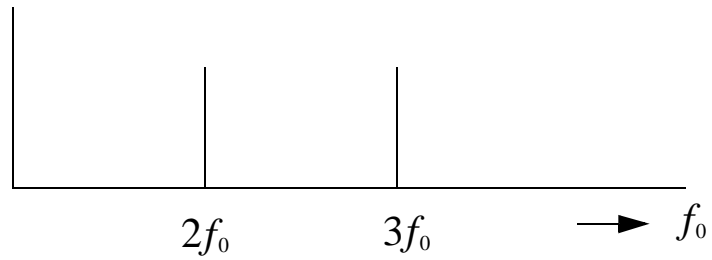
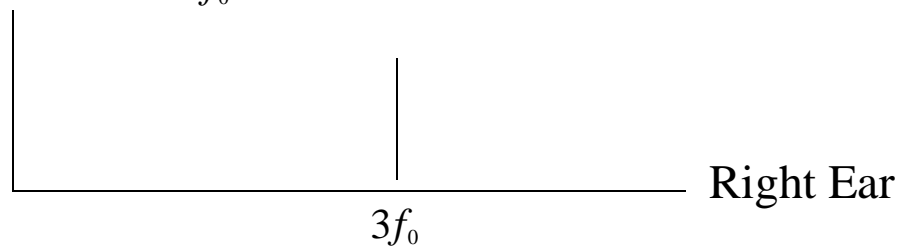

Figure 16.6 : Ritsma's Setup to Determine Dominant Frequencies for Pitch Perception.

Houtsma and Goldstein



- Play into both ears.



PHYSIOLOGICAL DATA FROM MILLER AND SACHS
 "Representation of Voice Pitch in Discharge
 Patterns of Auditory Nerve Fibers"

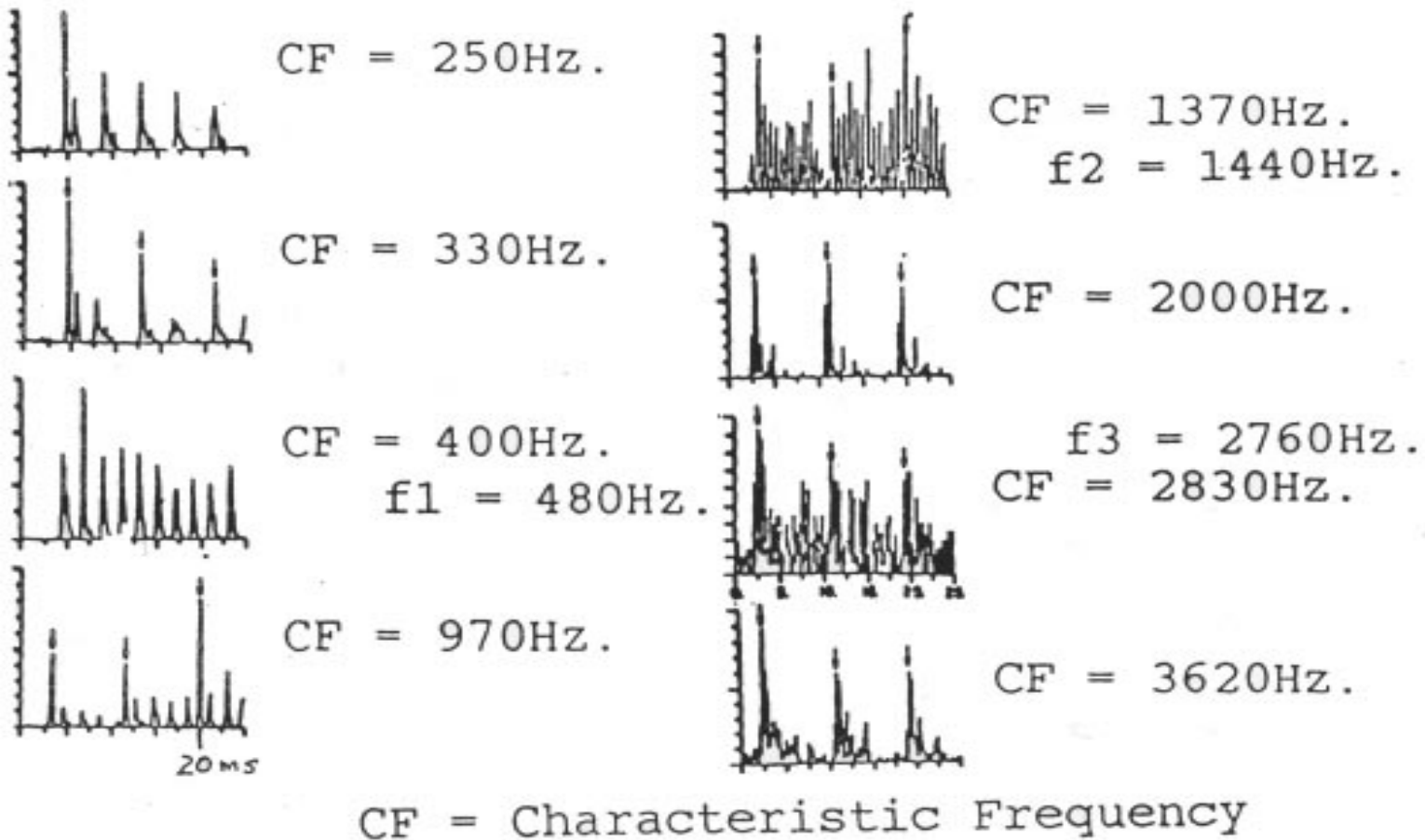

Figure 16.7 : Histograms of Spiking Intervals

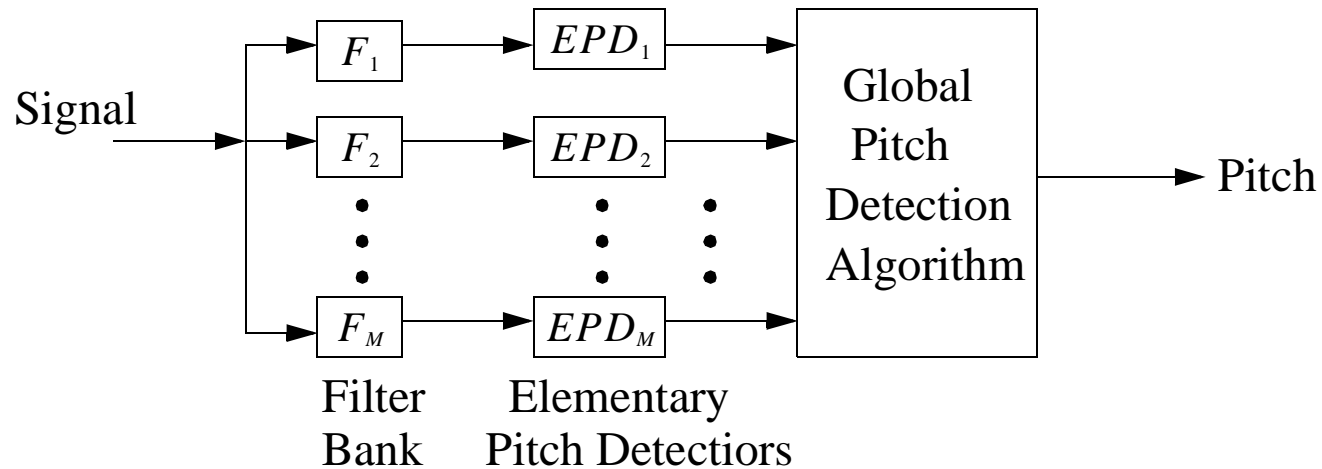

Figure 16.9 : Block Diagram of the Periodicity Model.

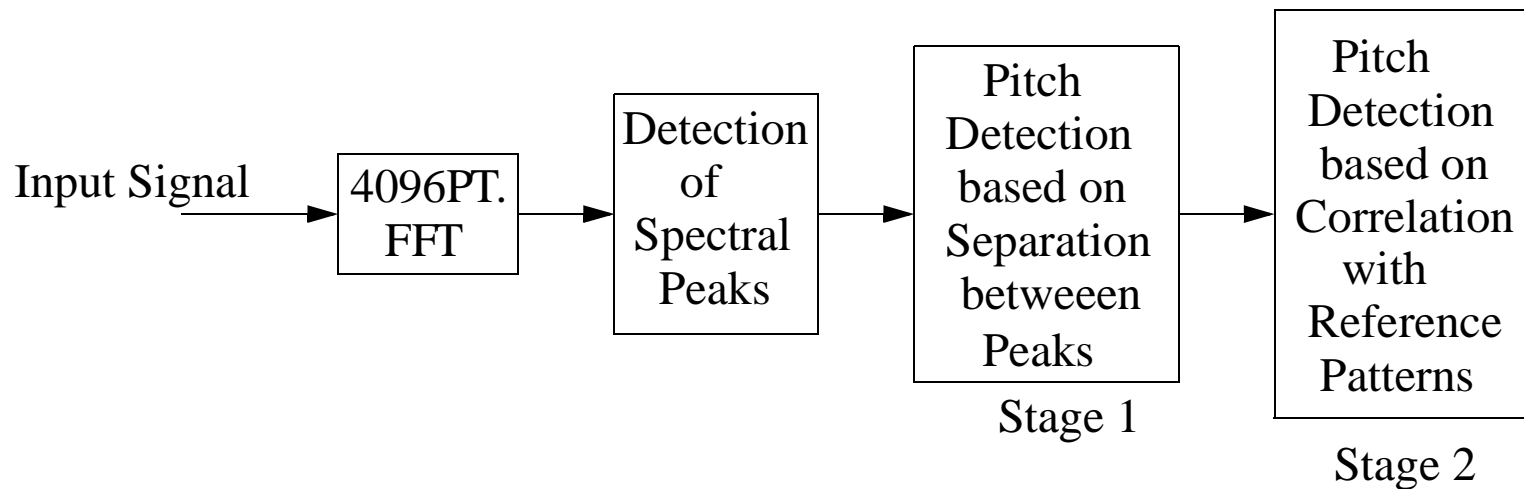

Figure 16.10 : Block Diagram of the Place Model.

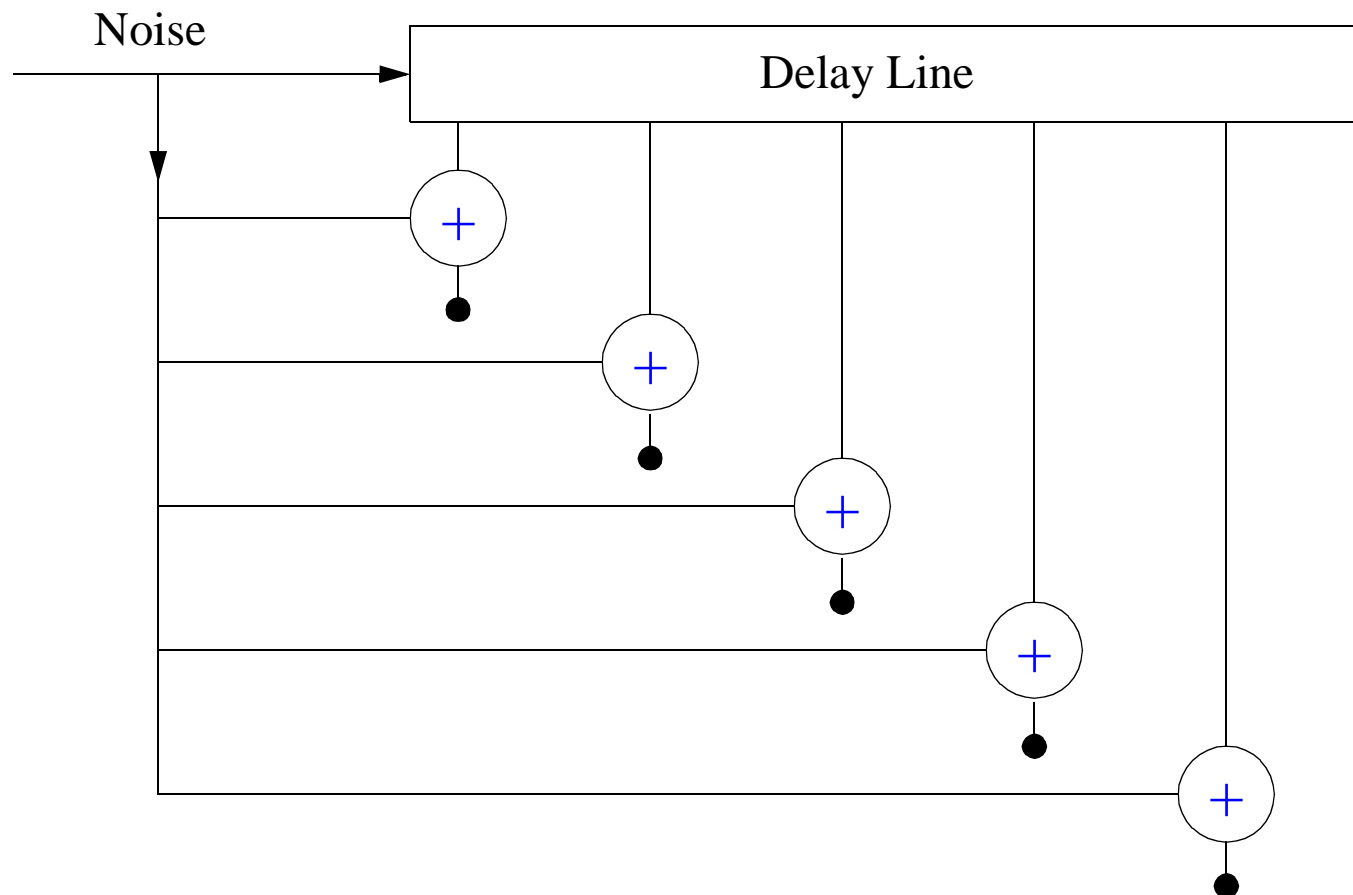

Figure 16.13 : Comb-Filtered Noise with Different Delays
(Perceived Pitch is Inverse to Delays)

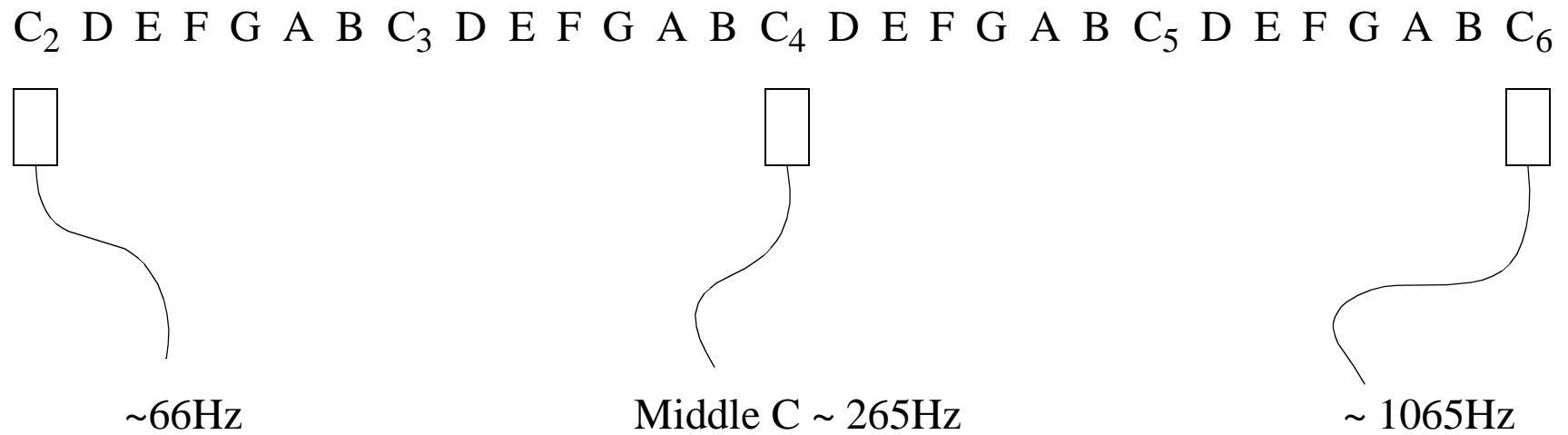

Figure 16.14 : Comb-Filtered Noise Demonstation.